

STANDARD CONFIGURATION		
ITEM NO.	DESCRIPTION	QTY.
1	3 PUMP SHELF BASE	1
2	LID, 3 PUMP SHELF	1
3	PLEXIGLASS WINDOW, 11-3/4" X 23-1/2" X 1/8"	1
4	NO. 6 X 1/2" FLAT HEAD SCREW	12
5	LID PROP, Ø1/2" X 25-3/8", FIBERGLASS	1
6	1/4"-20 X 3/4" SCREW, FLAT HEAD, SS	6
7	SINGLE PUMP PLATE, 29-1/4" X 12" X 1/2"	1
8	HINGE ROD, Ø1/4" X 20-1/2", ALUM	1
9	1/4" AXLE NUT (CAP NUT), ALUM.	2
10	2" FNPT SPIN WELD FITTING, PE, BLACK	4
11	2" MPT PLUG, PE, BLACK	4
12	ANGLE BRACKETS, ALUM, 1-1/2" X 1-1/2"	4
13	WASHER	4
14	1/4"-20 X 5/8" PHILLIPS PAN HEAD, SS	4
15	1/4" FLAT WASHER, SS	2
16	1/4"-20 X 1-1/2" PHILLIPS ROUND HEAD, SS	2
17	1/4" NPT THREADED HEX SOCKET PLUG, HDPE, BLACK	2
18	1/4" FNPT FLUSH SPIN WELD FITTING, PE, BLACK	2
19	MOLD-IN GRAPHIC	1

PCS 3.0	PART NUMBERS	
	BLUE	NATURAL
STANDARD	253-30843	253-30844
W/ DIVIDER*	253-29460	253-29458

*SEE OPTIONAL FEATURES, SHEET 2

- NOTES:**
- MATERIAL:** LLDPE 8460, **COLOR:** , **FINISH:** SHOT PEEN
 - PART WEIGHT:** APPROX. 58 LBS.

PROPRIETARY AND CONFIDENTIAL
 THE INFORMATION CONTAINED IN THIS DRAWING IS THE SOLE PROPERTY OF PEABODY ENGINEERING. ANY REPRODUCTION IN PART OR AS A WHOLE WITHOUT THE WRITTEN PERMISSION OF PEABODY ENGINEERING IS PROHIBITED.

UNLESS OTHERWISE SPECIFIED:
 DIMENSIONS ARE IN INCHES
 TOLERANCES:
 FRACTIONAL ± 1/8"
 ONE PLACE DECIMAL ± .25"
 TWO PLACE DECIMAL ± .125"
 THREE PLACE DECIMAL ± .063"

TANK MATERIAL:
LLDPE 8460

INNER TANK S/N:
 OUTER TANK S/N:
 CUSTOMER PO#

DO NOT SCALE DRAWING

NAME	DATE	PROJECT: 3 PCS PUMP SHELF	
DRAWN: RFR	01/03/14	CUSTOMER: PEABODY STANDARD	
CHECKED:		SITE/LOCATION:	
ENG APPR.:		DRAWING#: SEE TABLE	
MFG APPR.:		SIZE: B	DESC.: PCS 3.0 STANDARD
Q.A.:		SCALE: 1:12	REV.: E
COMMENTS:		SHEET 1 OF 3	



8 7 6 5 4 3 2 1

OPTIONAL ITEMS

ITEM NO.	DESCRIPTION	QTY.
1	CONTROLLER MOUNT PLATE (OPTIONAL), LG, 10-7/16" X 8-3/4" X 1/4"	1
2	WEATHER STRIP GASKET SEAL (SHIPPED LOOSE)	1
3	DIVIDER SHIELD, 1/4" (OPTIONAL, FOR USE WITH TWO PUMP PLATES)	1
4	PUMP PLATE, LG, 19" X 12" X 1/2" (OPTIONAL, FOR USE WITH DIVIDER SHIELD)	1
5	PUMP PLATE, SM, 9-1/2" X 12" X 1/2" (OPTIONAL, FOR USE WITH DIVIDER SHIELD)	1
22	2" MPT PLUG, PE, BLACK	4
23	1/4"-20 X 1-1/2" SECURITY BUTTON HEAD, SS	2

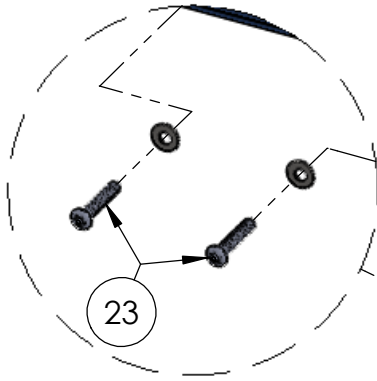
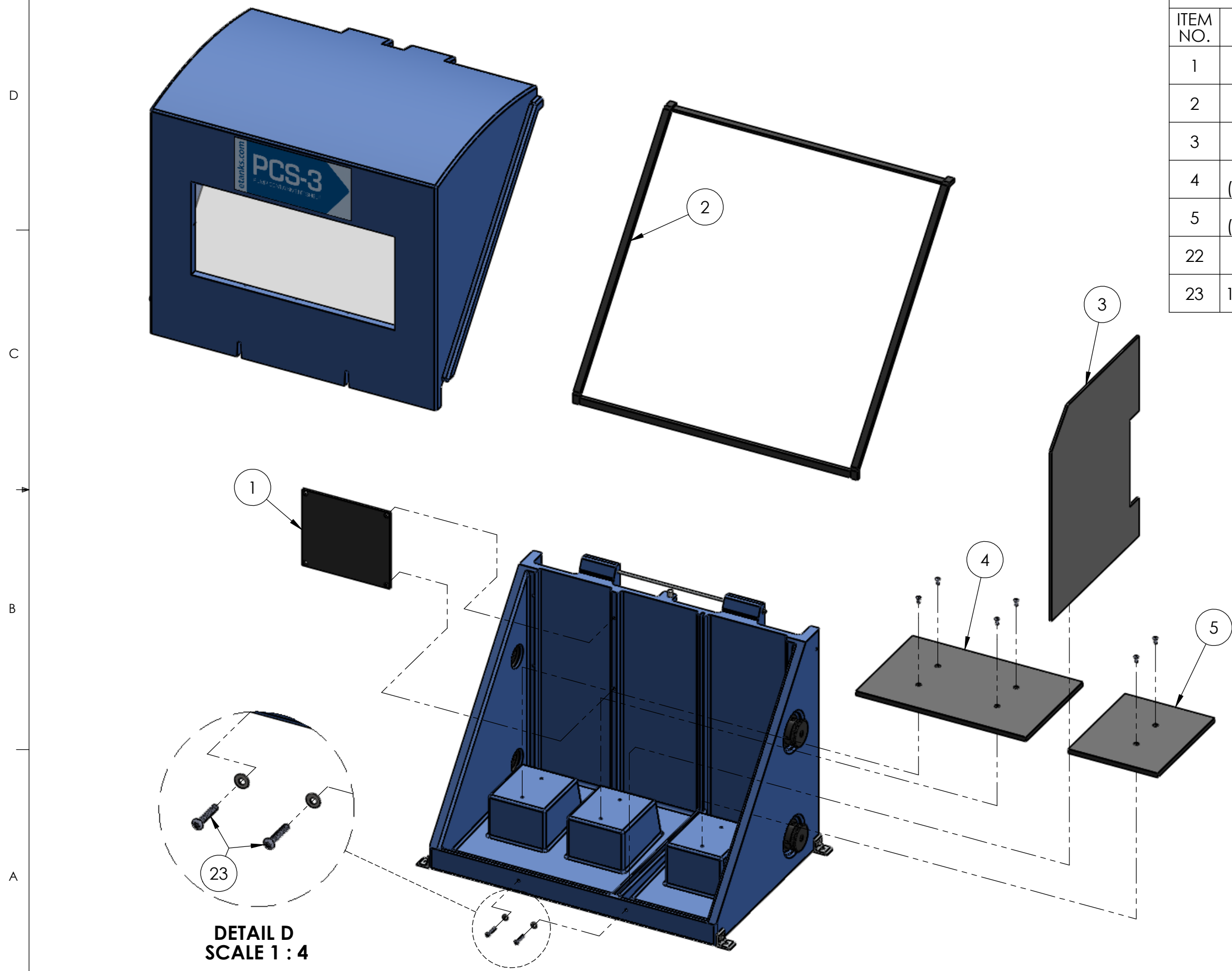

**DETAIL D
SCALE 1 : 4**



PROJECT:
3 PCS ASSY, REV. E, CUSTOMER PRINT

SCALE: 1:10 | SHEET 2 OF 3

8 7 6 5 4 3 2 1

